

CLIMALINE

Free Floating Ceiling Linear

Panel, smooth or perforated

Technical Data	85
Construction	86
Assembly	88
Hydraulic Components	89
Performance Data	90
Design	90
Hydraulic Connection	91
LinearLux LED Light	92
Technical Data LinearLux	93
Construction LinearLux	94
CLIMALINE Ceiling Systems Checklist	96



Annex

Measurement
& Contr. Techn.

Air Systems

Cool Sets
Water Chillers

Acoustical
Effectivity

Free Floating
Ceiling Linear

Free Floating
Ceiling Mono

Panel Ceiling
Linear

Metal Tile
Ceilings

Gypsum Tile
Ceilings

Gypsum
Planked Type

D
Gypsum

Planked Type
A

The design of the area to be tempered with free floating ceilings usually focuses on the window axes of a building. The smallest control zones can therefore be outlined and planned in accordance with the requirements for use. A defined power density can be planned per axle and controlled via the measurement and control technology as required.

Product Advantages

Considerably higher performance
Highly sound-absorbing
Integrated workstation light
Easy planning of control zones
Simple hydraulic control

Areas of Application

Office floors
Training/seminar rooms
Sales areas
Open-plan offices
Meeting rooms

Technical Data

Colouring	according to RAL
Operational weight	approx. 15.0 kg/m ²
Water content	approx. 1.0 l/m ²
Pipe meander	copper 10 x 0.6 mm
Heat flux profiles	aluminium 51.5 mm wide

System Constructions

Linear arrangement of panels
Strengthened via supporting rails
Suspended by stainless steel ropes
Perforated or smooth design

Technical Properties

Building material class

A2-s1, d0 according to EN 13501-1

Light reflection

Approx. 82 % (similar to RAL 9010)

Sound absorption

According to DIN EN 20354 (ISO 354)
ASTM C 423

Performance

Heating output according to DIN EN 14037
Cooling output according to DIN EN 14240

Durability

Stress class C
according to DIN EN 13964 table 7 and 8
Diffusion resistant according to DIN 4726



EN 13964

The panels are
manufactured
according to the



quality standard

Construction

Each CLIMALINE free floating ceiling Linear is equipped with a pressed-in register. We either deliver a distributor for each free floating ceiling or we combine several free floating ceilings via one distributor. We plan the hydraulic connection and the individual control of each control zone to your specifications.

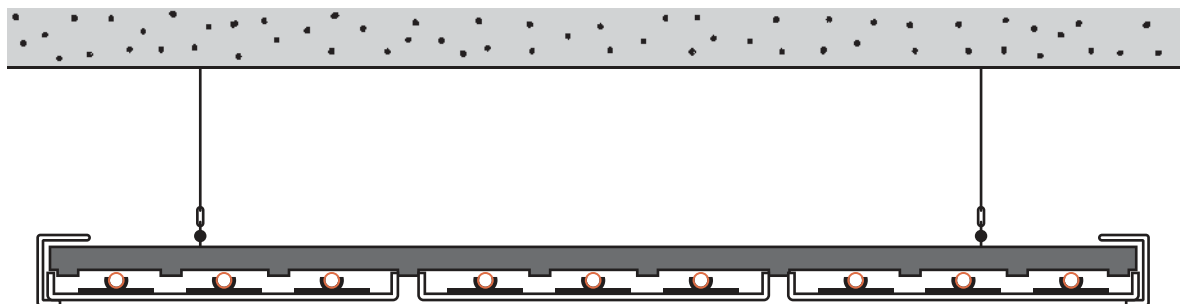

**Visible side
of the free floating ceiling**

The visible area of the CLIMALINE Climaline free floating ceiling Linear is available in both a smooth and a perforated design.



Panel and register dimen-

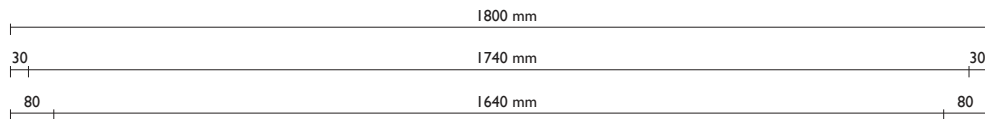
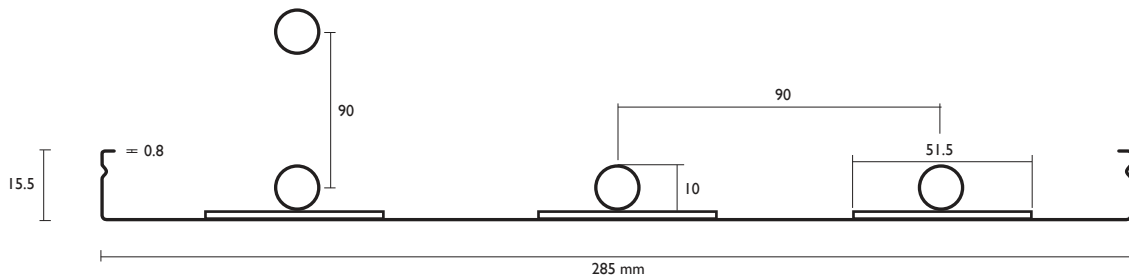

Assembly

CLIMALINE free floating ceilings Linear can be mounted either individually or combined according to the planned use and room geometries. Here, too, we plan the design and hydraulic calculations according to your specifications.

Free floating ceiling mounted separately

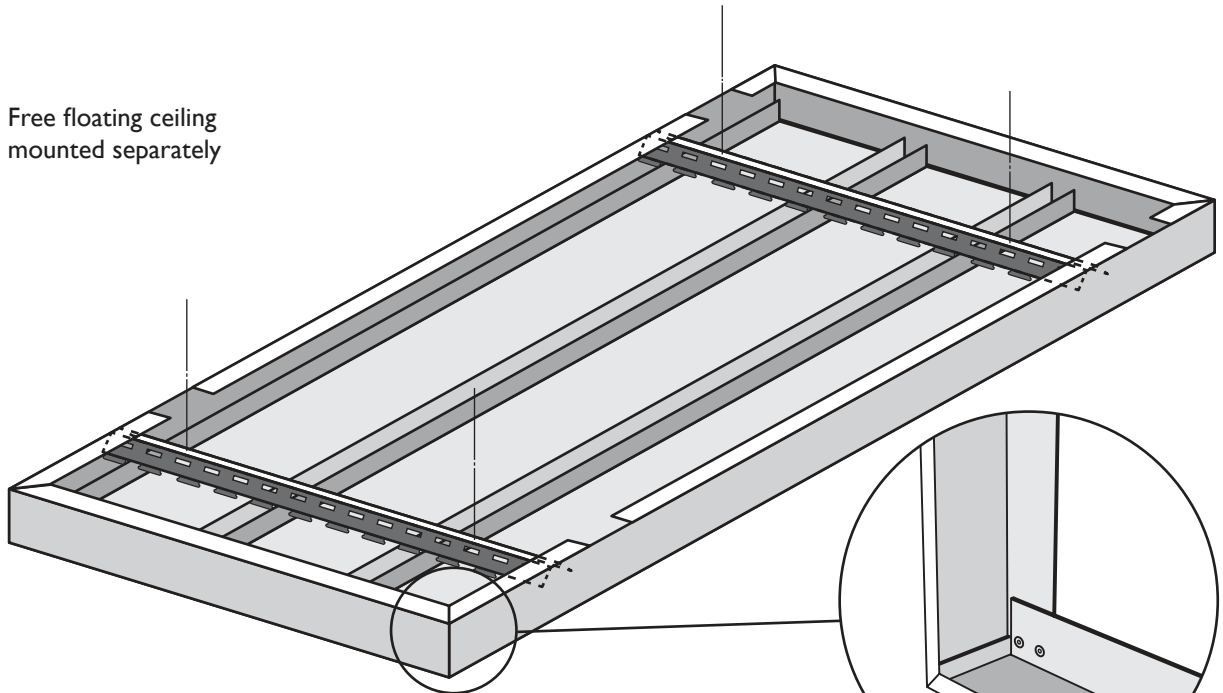

Free floating ceilings mounted side by side

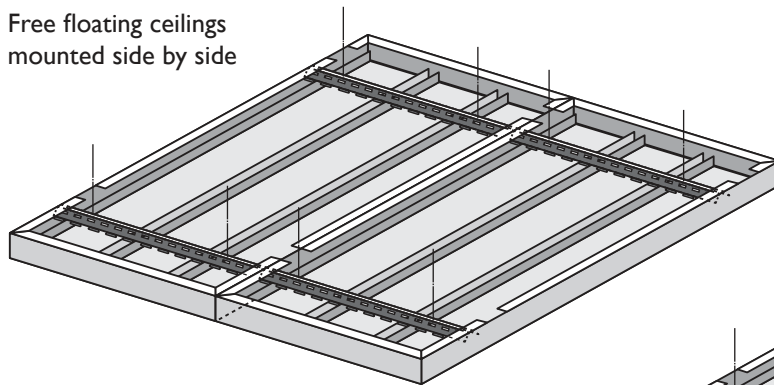

Back lip to edge mitre
(view: visible side)

Free floating ceilings mounted one behind the other

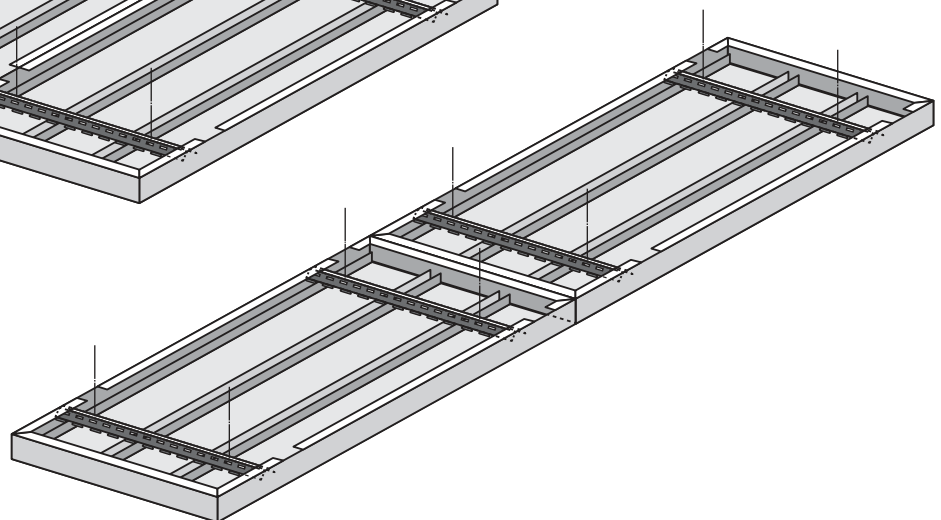

Hydraulic Components

Unless otherwise explicitly requested, we forego internal piping in the rooms in the hydraulic design. We thus remain true to our idea of equipping each control area with a distributor.

Designation	Art. no.	Material	Dimension	Illustration
Connection hoses between the registers Length: 0.6 m Length: 0.8 m Length: 1.0 m Length: 1.5 m Length: 2.0 m Length: 2.5 m	293493 293495 293497 293532 293587 293597	Stainless steel/polyethylene	Fitting 10 mm	
Hoses connecting the registers to the distributor Length: 1.0 m Length: 1.5 m Length: 2.0 m Length: 2.5 m Length: 3.0 m Length: 4.0 m Length: 5.0 m Length: 6.0 m Length: 7.0 m Length: 8.0 m Length: 10.0 m	293575 293581 293586 293592 313515 313516 313517 313518 313519 313520 313521	Stainless steel/polyethylene	Fitting 10 x 12 mm	
CLIMALINE VR adapter for distributor, 2 pieces per circuit	317807	Plastic	16 mm	
CLIMALINE brass adapter for internal piping to flex hose, 2 pieces per circuit	317806	Brass	16 x 12 mm	
CLIMALINE circuit distributor for 2 circuits for 3 circuits for 4 circuits for 5 circuits for 6 circuits for 7 circuits for 8 circuits for 9 circuits for 10 circuits for 11 circuits for 12 circuits	317793 317794 317795 317796 317797 317798 317799 317800 317801 317802 317803	Stainless steel	for VR adapter 16 mm	

Performance Data

Cooling output acc. to DIN EN 14240

CLIMALINE free floating ceiling Linear	
Pipe row spacing	90 mm
Δt	10 Kelvin
Cooling output	132 Watt
Active area ratio	0.88

Heating output acc. to DIN EN 14037

CLIMALINE free floating ceiling Linear	
Pipe row spacing	90 mm
Δt	15 Kelvin
Heating output	143 Watt
Active area ratio	0.88

Design

The following tables show the pressure losses and flow depending on the cooling capacity per free floating ceiling at the specified system temperatures. The calculation of pressure losses and the required mass of water is explicitly performed for every application.

Cooling System: Free floating ceiling Linear 1800 x 1185 mm

System temperature						
Supply temperature	15 °C	15 °C	15 °C	16 °C	16 °C	16 °C
Return temperature	17 °C	18 °C	19 °C	18 °C	19 °C	20 °C
Room temperature	26 °C	26 °C	26 °C	26 °C	26 °C	26 °C
Cooling output per free float. ceiling	277.30 W	263.40 W	249.60 W	249.60 W	235.70 W	221.80 W
Mass flow per free float. ceiling	108.37 kg/h	68.82 kg/h	48.90 kg/h	97.80 kg/h	61.58 kg/h	43.47 kg/h
Pressure loss per free float. ceiling	179.59 mbar	80.75 mbar	44.40 mbar	149.35 mbar	66.47 mbar	36.13 mbar

Heating System: Free floating ceiling Linear 1800 x 1185 mm

System temperature						
Supply temperature	35 °C	35 °C	35 °C	32 °C	32 °C	32 °C
Return temperature	32 °C	30 °C	28 °C	29 °C	27 °C	25 °C
Room temperature	20 °C	20 °C	20 °C	20 °C	20 °C	20 °C
Heating output per free float. ceiling	274.50 W	254.20 W	233.80 W	213.50 W	193.20 W	172.80 W
Mass flow per free float. ceiling	71.72 kg/h	39.86 kg/h	28.47 kg/h	55.78 kg/h	30.29 kg/h	19.35 kg/h
Pressure loss per free float. ceiling	86.79 mbar	31.04 mbar	17.23 mbar	55.91 mbar	19.21 mbar	8.76 mbar

Hydraulic Connection

The hydraulic connection of the CLIMALINE free floating ceilings Linear is explicitly planned for every area of application.

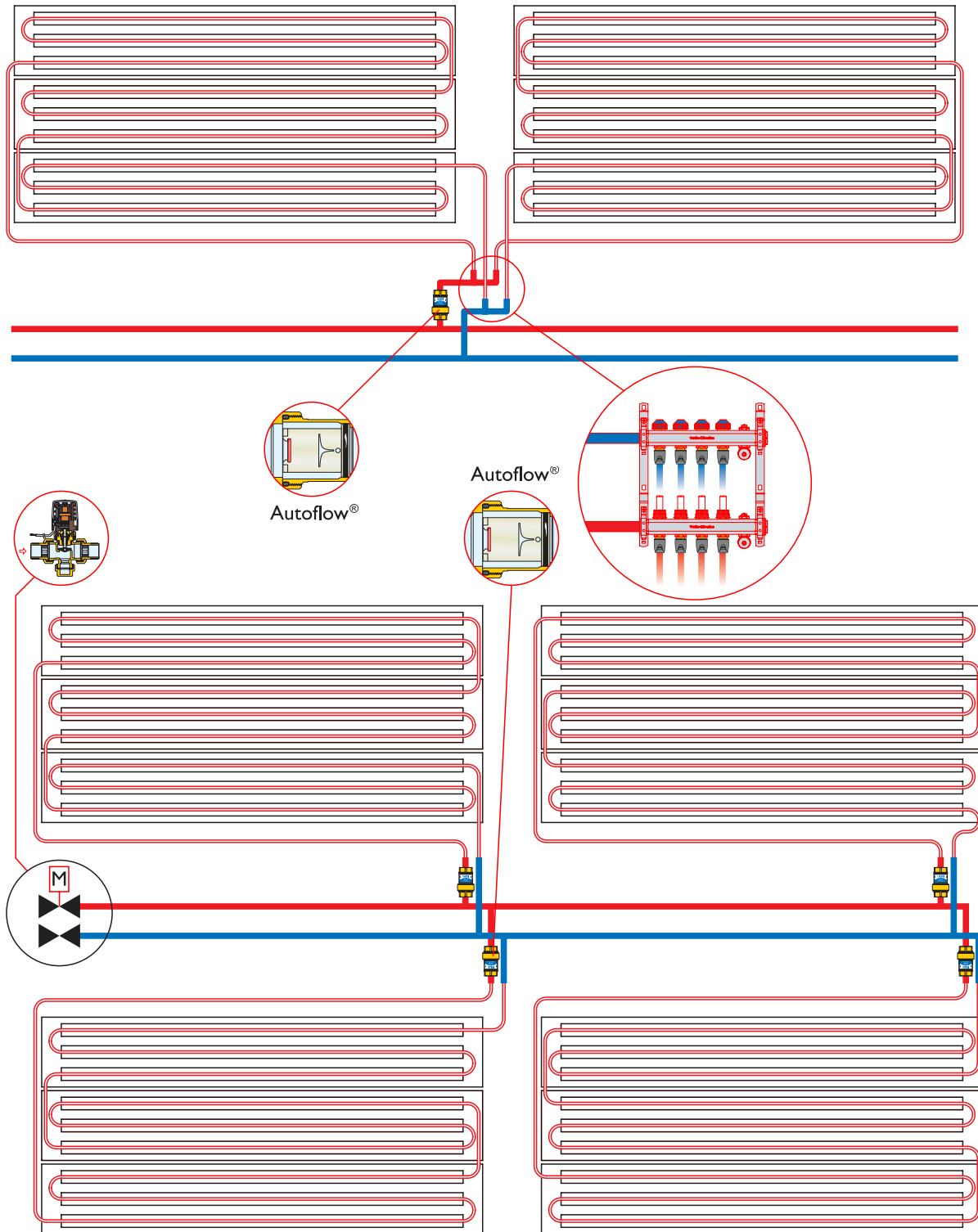

- Planked Type A
- D Gypsum
- Gypsum Planked Type
- Gypsum Tile Ceilings
- Metal Tile Ceilings
- Panel Ceiling Linear
- Free Floating Ceiling Mono
- Free Floating Ceiling Linear**
- Acoustical Effectivity
- Cool Sets Water Chillers
- Air Systems
- Measurement & Contr. Techn.
- Annex

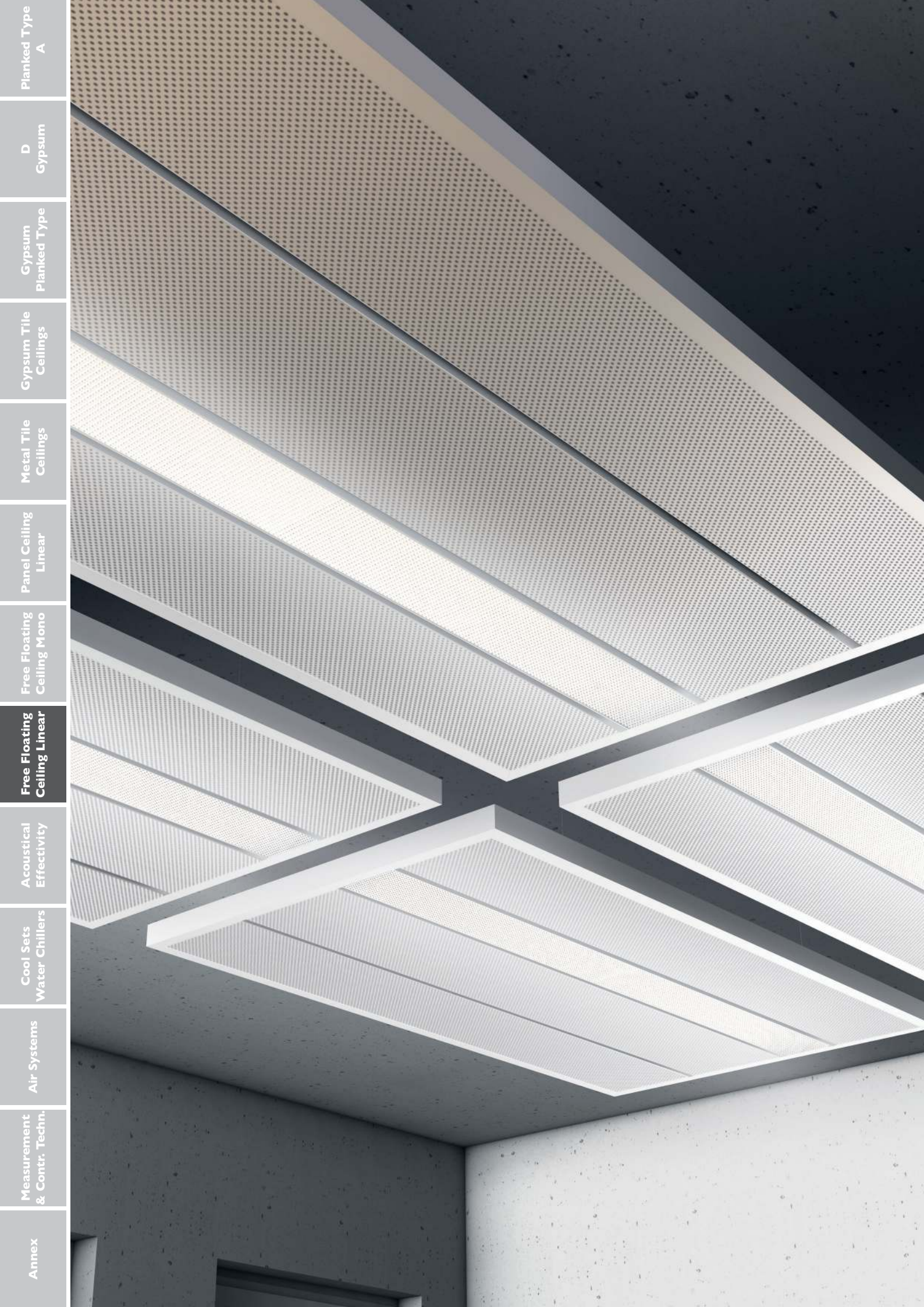

Annex

Measurement
& Contr. Techn.

Air Systems

Cool Sets
Water Chillers

Acoustical
Effectivity

Free Floating
Ceiling Linear

Free Floating
Ceiling Mono

Panel Ceiling
Linear

Metal Tile
Ceilings

Gypsum Tile
Ceilings

Gypsum
Planked Type

D
Gypsum

Planked Type
A

LinearLux LED Light

As a smart addition to our free floating ceiling Linear the symmetrically integrated LinearLux LED light has been developed. In contrast to closed thermally activated ceilings, where the lights mostly are suspended, in free floating systems it makes sense to integrate the lighting.

Product Advantages

- Lay-in assembly
- Flat case of aluminium
- Freely dimmable
- Suitable for workstations
- Highly efficient LED technology

Areas of Application

- Workstations
- Multifunction rooms
- Open-plan offices
- Foyers
- Other workplaces

Technical Data

System suitability	Free floating ceiling Linear
Material case	extruded aluminium profile
Colour case	RAL 9006 (white aluminium)
Operational weight	4.5 kg/m
Assembly dimension	150 mm wide, up to 6000 mm long
Thickness	35 mm
Coverings	micro prism or opal

Technical Properties

Protection type	IP 20
Protection class	I
Power input	23 W per metre (up to 43 W)
System efficiency	up to 130 lm/W
Supply data	230 V AC, 50/60 Hz
Mounting LED	LED 21 W per metre (up to 40 W)
Light colours	3000 K (warm white), 4000 K (neutral white)



Construction

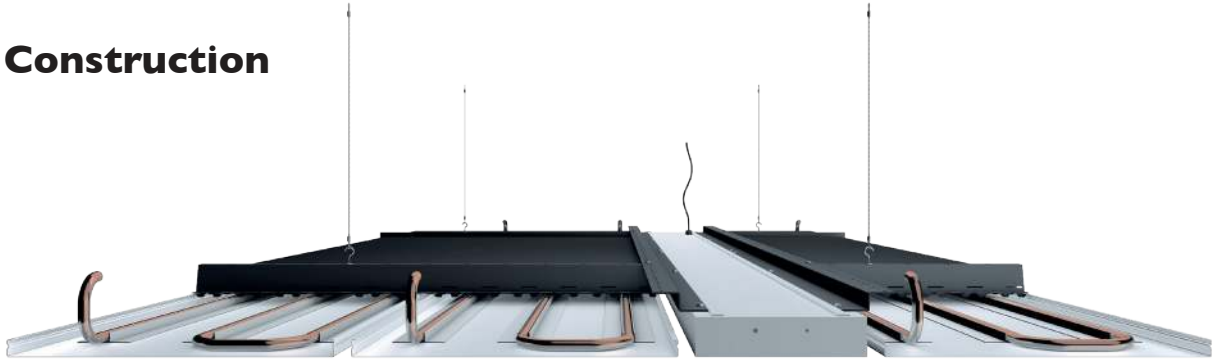

Assembly of light LinearLux between the panels of the Climaline free floating ceiling Linear

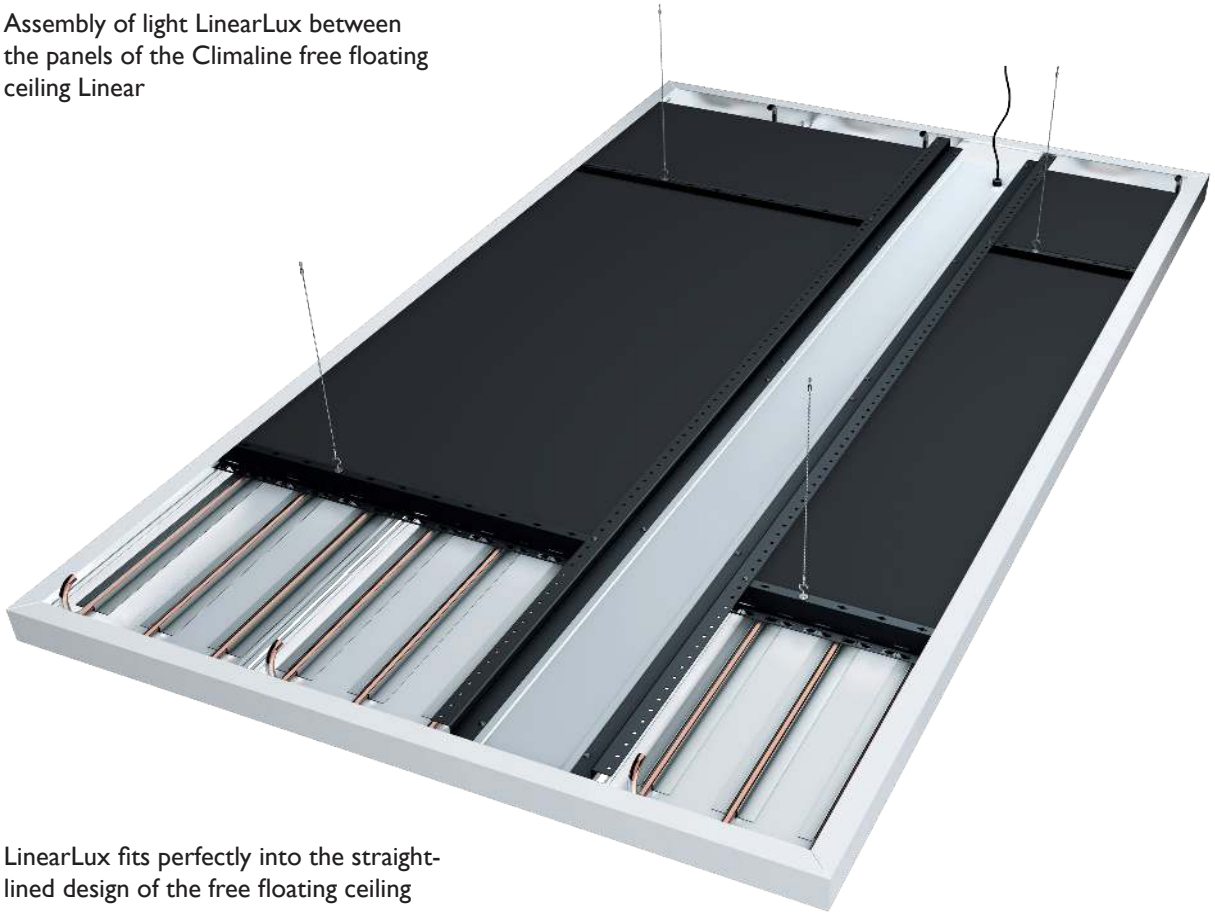

LinearLux fits perfectly into the straight-lined design of the free floating ceiling

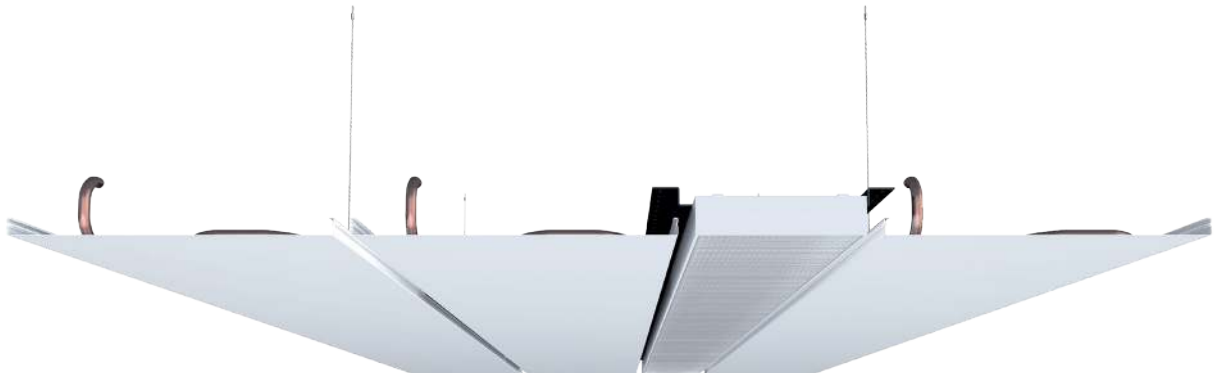

Light distribution



Fully surfaced light covering with highly efficient micro prism screen for anti-glare light distribution



Fully surfaced light covering with opal PMMA-screen for widely spread light distribution

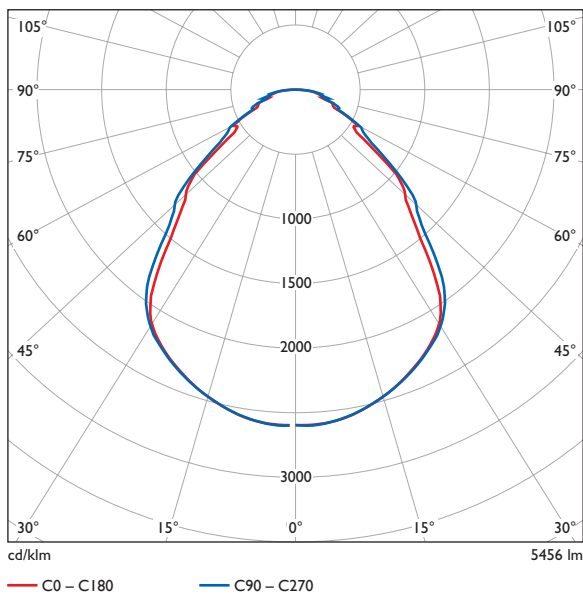

Light distribution curve micro prism

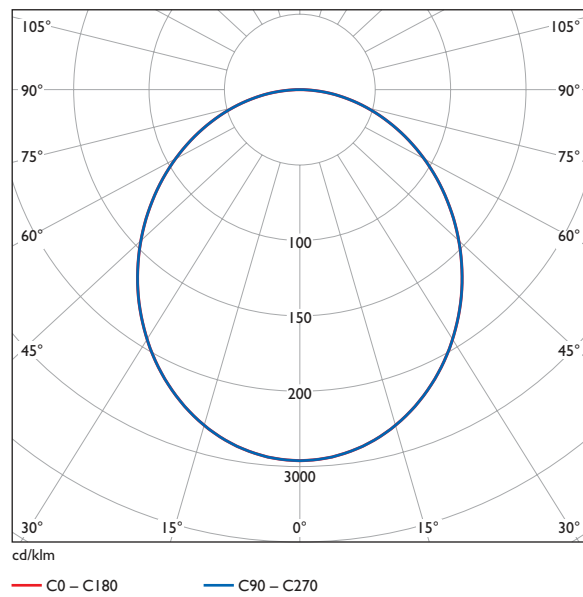

Light distribution curve opal

Construction and assembly measures

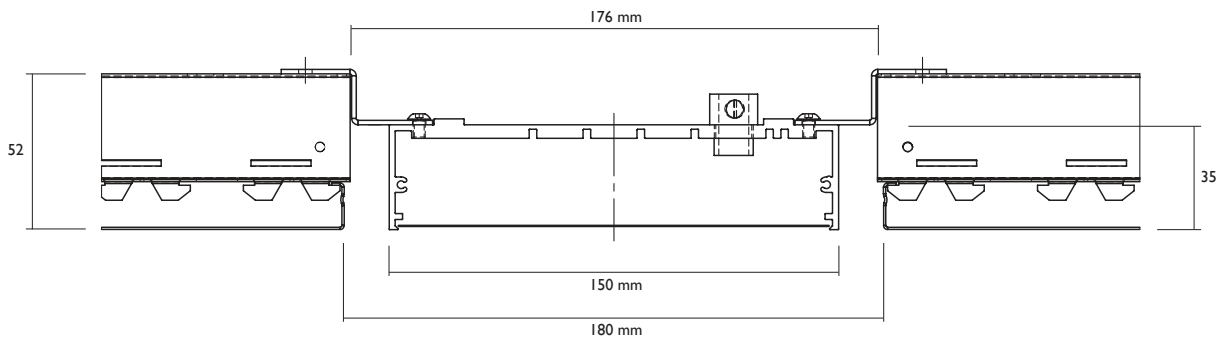

CLIMALINE Ceiling Systems Checklist

1. System selection

- Gypsum ceiling system
 Metal ceiling system
 Free floating ceiling
 Thermo Panel 4T

2. System

- Suspended assembly
 Heating → System temperature: supply: _____ return: _____
 Cooling → System temperature: supply: _____ return: _____
- Direct assembly
 Heating → System temperature: supply: _____ return: _____
 Cooling → System temperature: supply: _____ return: _____

3. Building

- Floor plan
 PDF format
 DWG format
- Heating load calculation
 available
 required*
 fixed value: _____ watts/m²
- Cooling load calculation
 available
 required*
 fixed value: _____ watts/m²

4. Measurement and control technology

- Climate control
 wired → Comfort Object
 wireless → Comfort Object
- Accessories
 Zone valve
 Automatic mass flow limiter

*A list of components with U-values and a floor plan in DWG format are required to calculate heating and cooling loads.